

# 440 Seal Installation Instructions

## EQUIPMENT PREPARATION

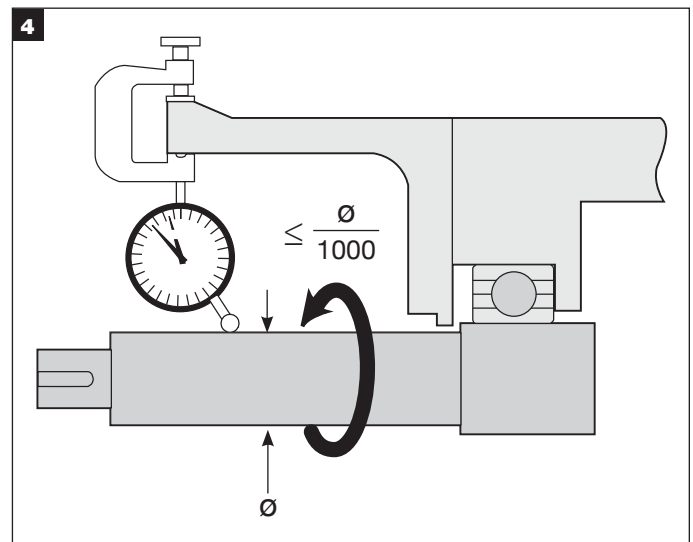
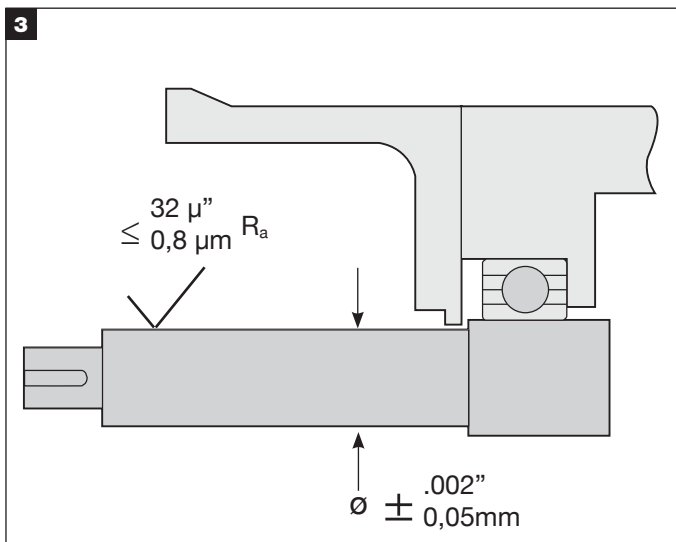
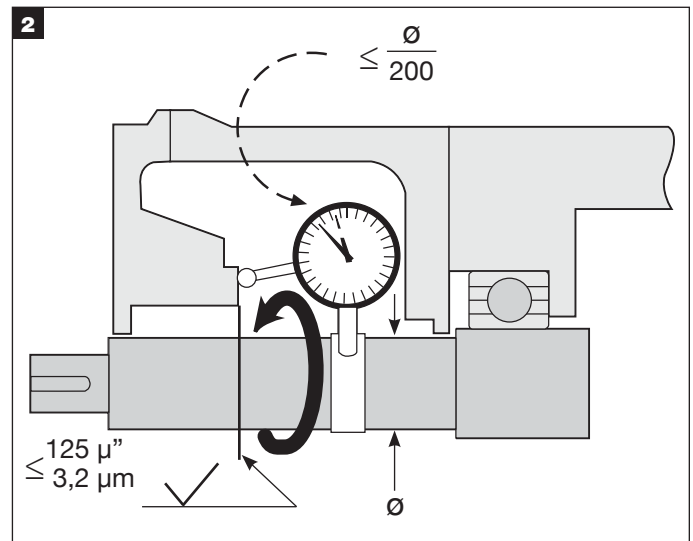
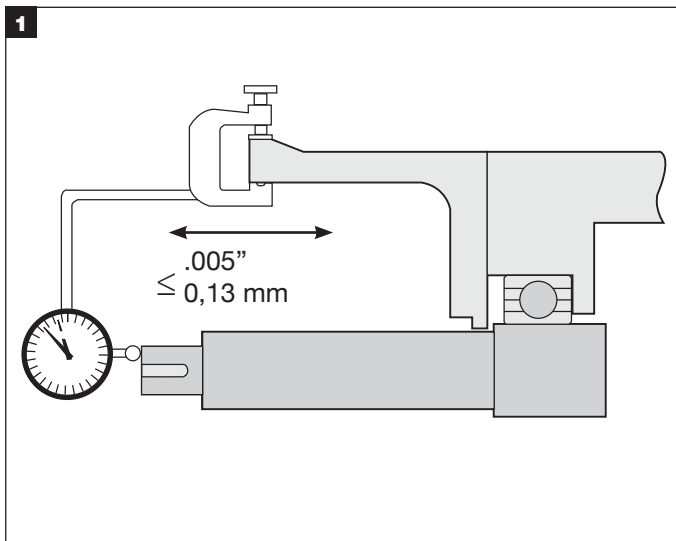

## CAUTIONS

These instructions are general in nature. It is assumed that the installer is familiar with seals and certainly with the requirements of their plant for the successful use of mechanical seals. If in doubt, get assistance from someone in the plant who is familiar with seals or delay the installation until a seal representative is available. All necessary auxiliary

arrangements for successful operation (heating, cooling, flushing) as well as safety devices must be employed. These decisions are to be made by the user. The chemical listing is intended as a **general** reference for this seal **only**. The decision to use this seal or any other Chesterton seal in a particular service is the customer's responsibility.

## SEAL INSTALLATION

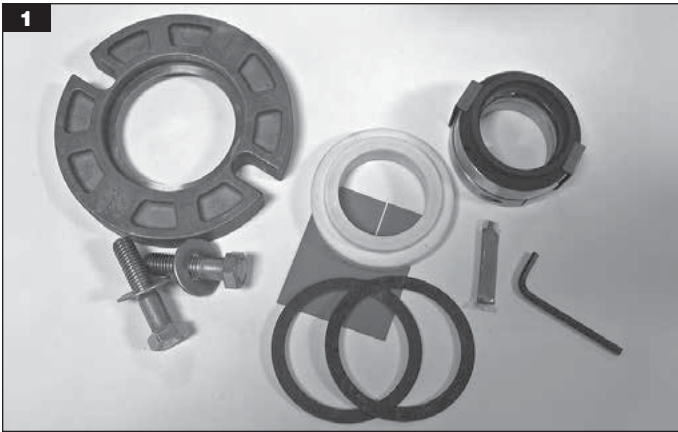

Prepare 440 Rotary Unit, Stationary Unit and Gland for installation. **See Note re:chem listing item no. 072369.**

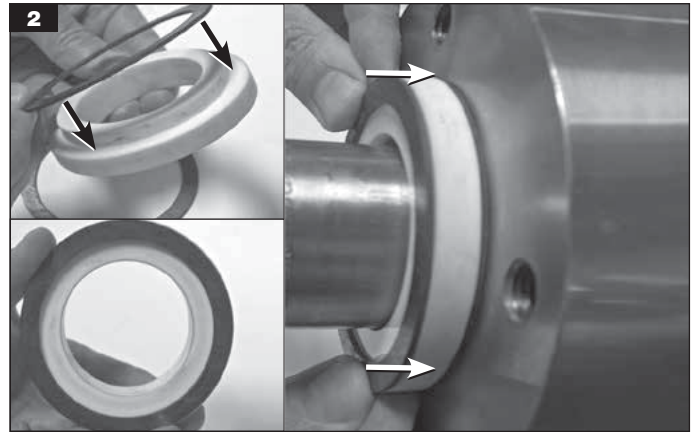

Install gaskets on to stationary unit; slide stationary unit on to shaft.

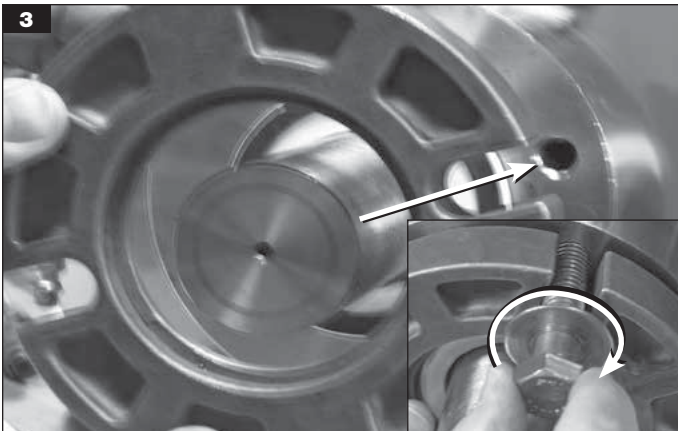

Slide gland onto shaft, aligning gland slots with bolt holes on equipment. Install bolts/washers and finger tighten.

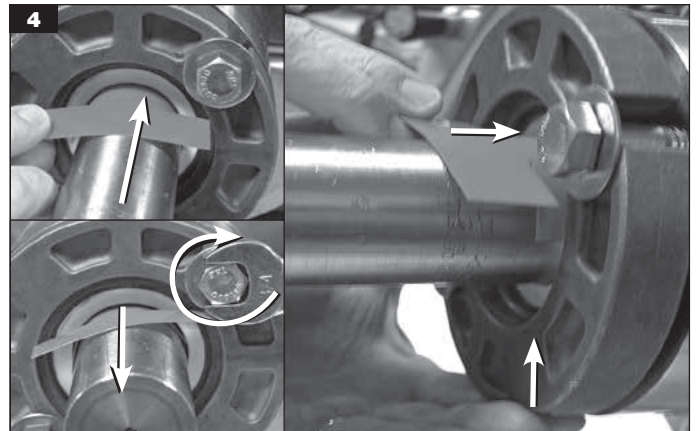

Insert centering shim between shaft and stationary ID, pressing up on gland to allow alignment. Tighten gland bolts 1 flat; remove centering shim.

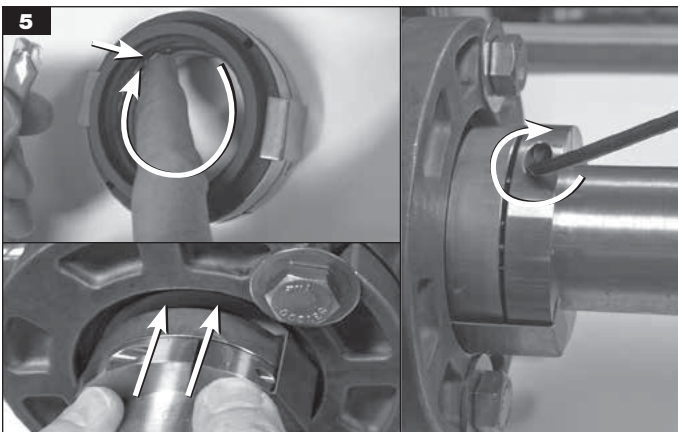

Apply a thin film of grease to the 440 O-ring and slide rotary unit on to shaft. Press back of rotary unit to seat faces; tighten cap screw in drive ring.

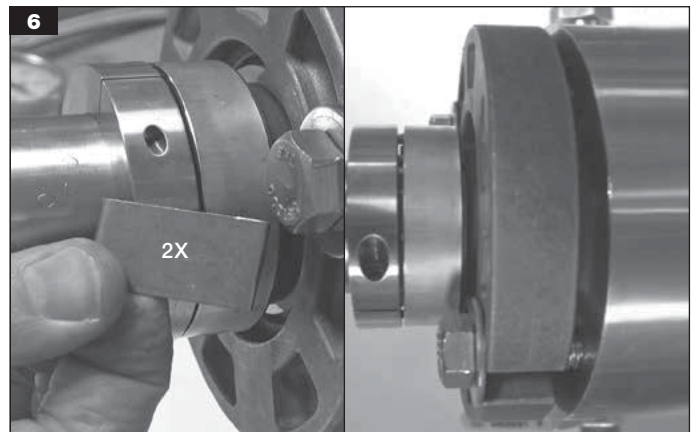

Remove the 2 retaining clips. Installation is complete. **Important: If seal leakage is visible at startup, tighten gland bolts 1 flat; continue to tighten 1 flat until leakage stops.**

## 440 DIMENSIONAL DATA

### Installing the 440 seal with L-Shape Stationary (Nose In) and 478 Gland\*

\*Stationary and Gland purchased separately from your Chesterton distributor

#### For seal sizes 1.875 in. (48 mm) and smaller:

1. Position 440 on shaft
2. Remove clips
3. Set spring gap 1/16 in. (1,5 mm)
4. Tighten clamp to shaft

#### NOTES:

1. O-ring compatibility: Check the chemical listing in "How to Use the Chemical Listing" booklet included with the seal to determine if the standard fluoroelastomer O-ring installed in the seal is compatible with the fluid being sealed. A spare ethylene propylene O-ring is supplied with the seal.
2. -15 (1.875) S-special available for use on Duriron Mk II GR11 pumps.
3. Metric designations on gland are for ISO stationaries and not for metric conversion of inch sizes. Use gland slots provided. Additional holes can be drilled when 4 bolts are required.
4. Consult Chesterton for gland used on shaft sizes larger than 2 5/8 (65 mm).

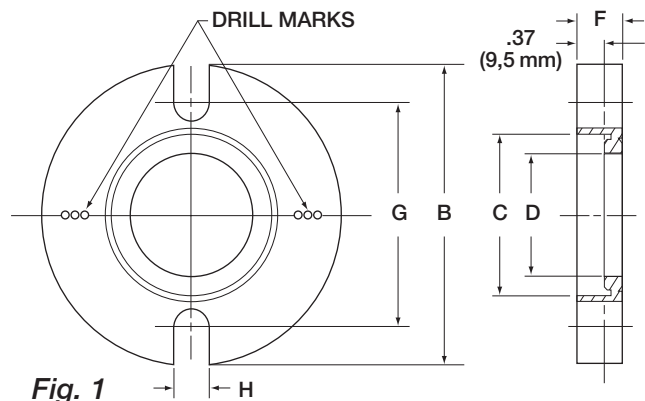

Fig. 1

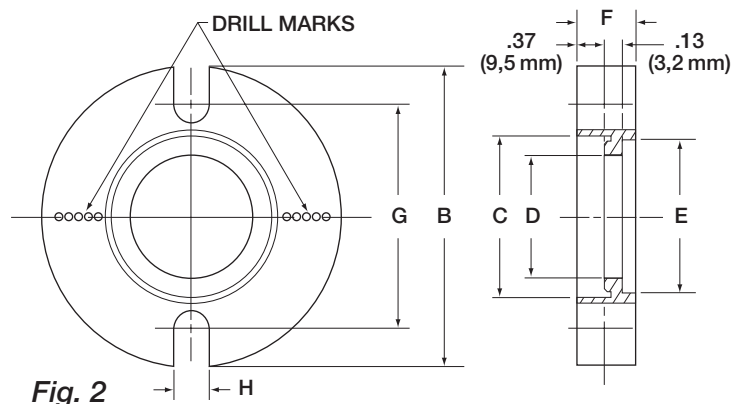

Fig. 2

#### INCH SIZES

SHAFT SIZE inch	REF FIG.	B MAX inch	C MIN inch	D MIN inch	E MIN inch	F inch	G MIN			DRILL MARKS FOR ADDITIONAL BOLT HOLES (Bolt Circle Dia. inch)	H inch
							3/8 in.	1/2 in.	5/8 in.		
1.000	1	4.11	2.13	1.63	-	.50	2.88	-	-	3.0, 3.25, 3.5	.438
1.125	1	4.24	2.25	1.75	-	.50	2.89	-	-	3.0, 3.25, 3.5	.438
1.250	1	4.36	2.38	1.94	-	.50	3.13	-	-	3.25, 3.5, 3.75	.438
1.375	2	4.49	2.44	2.02	2.44	.63	3.20	-	-	3.25, 3.5, 3.75, 4.0	.438
1.500	2	4.99	2.75	2.29	2.66	.63	3.51	-	-	3.5, 3.75, 4.0, 4.25, 4.5	.438
1.625	2	4.99	2.88	2.45	2.78	.63	3.50	3.62	-	3.75, 4.0, 4.25, 4.5	.575
1.750	2	5.49	3.13	2.57	2.99	.63	3.72	3.85	-	4.0, 4.25, 4.5, 4.75, 5.0	.575
1.875	2	5.49	3.25	2.77	3.11	.75	3.88	4.01	-	4.0, 4.25, 4.5, 4.75, 5.0	.575
2.000	2	5.99	3.50	2.88	3.23	.75	4.14	4.26	-	4.25, 4.5, 4.75, 5.0, 5.25	.575
2.125	2	5.99	3.75	2.96	3.36	.75	4.39	4.52	4.77	4.75, 5.0, 5.25	.687
2.250	2	6.24	3.88	3.00	3.48	.75	4.52	4.64	4.77	4.75, 5.0, 5.25, 5.5	.687
2.375	2	6.24	3.91	3.36	3.61	.75	4.55	4.67	4.80	5.0, 5.25, 5.5	.687
2.500	2	6.49	4.13	3.47	3.73	.75	4.78	4.90	5.03	5.0, 5.25, 5.5, 5.75	.687
2.625	2	6.49	4.25	3.55	3.86	.75	4.90	5.03	5.15	5.25, 5.5, 5.75	.687

#### METRIC SIZES

SHAFT SIZE		REF FIG.	B MAX mm	C MIN mm	D MIN mm	E MIN mm	F mm	G MIN			DRILL MARKS FOR ADDITIONAL BOLT HOLES (Bolt Circle Dia. mm)	H mm
inch	ISO mm							10 mm	12 mm	16 mm		
1.000	24, 25	1	105	54,0	41,3	-	12,7	74	-	-	76/83/89	.438
1.125	28	1	108	57,2	44,5	-	12,7	74	-	-	76/83/89	.438
1.250	30, 32, 33	1	111	60,3	49,3	-	12,7	80	-	-	83/89/95	.438
1.375	35	2	114	61,9	51,3	61,9	15,9	82	-	-	83/89/95/102	.438
1.500	38	2	127	69,9	58,2	67,5	15,9	90	-	-	89/95/102/108/114	11,1
1.625	40, 42	2	127	73,0	62,2	70,6	15,9	90	92	-	95/102/108/114	14,6
1.750	43, 45	2	140	79,4	65,3	75,8	15,9	95	98	-	102/108/114/121/127	14,6
1.875	48, 50	2	140	82,6	70,4	79,0	19,1	100	102	-	102/108/114/121/127	14,6
2.000	53	2	152	88,9	73,2	82,0	19,1	106	108	-	108/114/121/127/133	14,6
2.125	55	2	152	95,3	75,2	85,2	19,1	112	115	118	121/127/133	17,4
2.375	58, 60	2	159	99,2	85,3	91,6	19,1	116	119	122	127/133/140	17,4
2.625	65	2	165	108,0	90,2	97,9	19,1	125	128	131	133/140/146	17,4

## 440 DIMENSIONAL DATA

Seal sizes  $1\frac{5}{16}$  in to  $2\frac{5}{8}$  in. (24 mm to 65 mm)

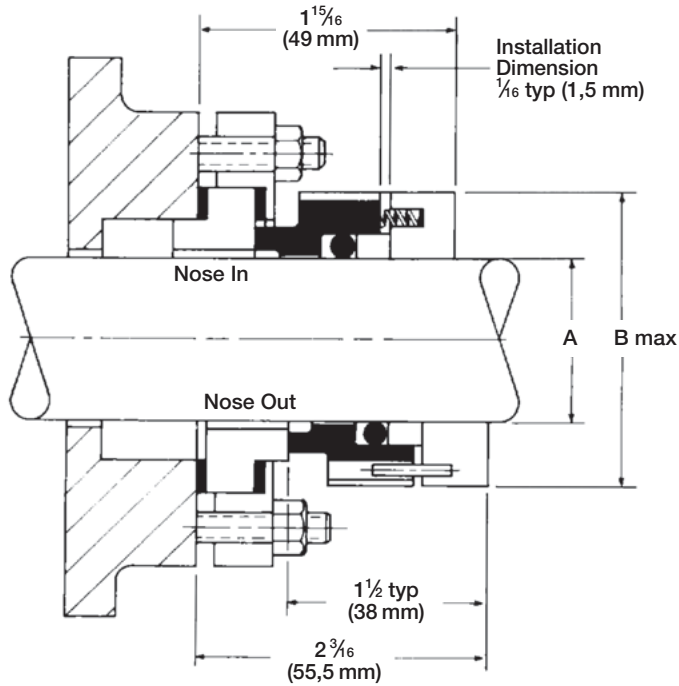

INCH: $1\frac{5}{16}$ inch to $2\frac{5}{8}$ inch				METRIC: 24 mm to 65 mm		
SHAFT SIZE A	DASH NO.	B MAX	O-RING	SHAFT SIZE A	B MAX	O-RING
$1\frac{5}{16}$	7.5	1.938	317	24	49,2	317
1	8	2.000	318	25	50,0	318
$1\frac{1}{8}$	9	2.125	320	28	54,0	320
$1\frac{1}{4}$	10	2.250	322	30	57,2	321
$1\frac{3}{8}$	11	2.375	324	32	57,2	322
$1\frac{7}{16}$	11.5	2.500	325	35	60,3	324
$1\frac{1}{2}$	12	2.500	325	38	63,5	325
$1\frac{5}{8}$	13	2.625	326	40	66,7	326
$1\frac{3}{4}$	14	2.750	327	42	69,9	326
$1\frac{7}{8}$	15	2.875	328	45	69,9	327
2	16	3.000	329	48	73,0	328
$2\frac{1}{8}$	17	3.125	330	50	76,2	329
$2\frac{1}{4}$	18	3.250	331	55	79,4	331
$2\frac{3}{8}$	19	3.375	332	60	85,7	332
$2\frac{1}{2}$	20	3.500	333	65	92,1	334
$2\frac{5}{8}$	21	3.625	334			

Seal sizes  $2\frac{3}{4}$  in to  $4\frac{1}{2}$  in. (70 mm to 110 mm)

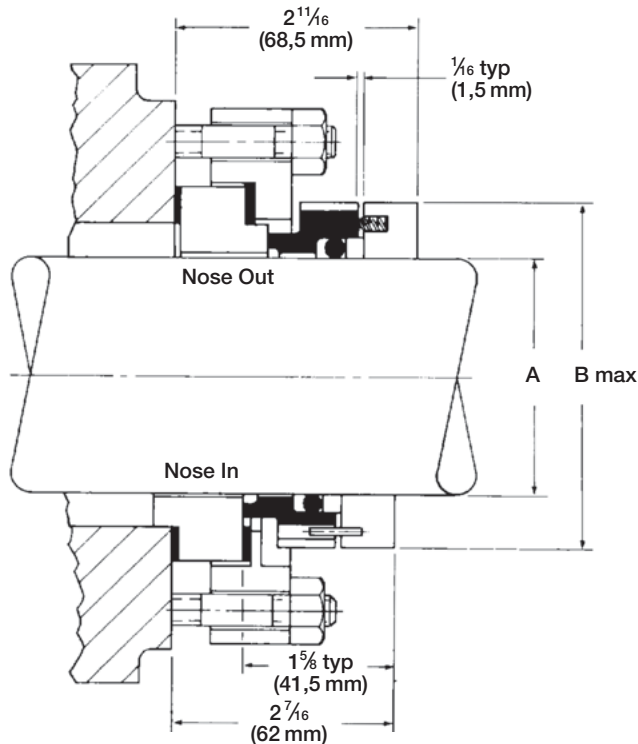

INCH: $2\frac{3}{4}$ inch to $4\frac{1}{2}$ inch				METRIC: 70 mm to 110 mm		
SHAFT SIZE A	DASH NO.	B MAX	O-RING	SHAFT SIZE A	B MAX	O-RING
$2\frac{3}{4}$	22	3.850	335	70	98,0	335
$2\frac{7}{8}$	23	3.980	336	75	104,4	337
3	24	4.110	337	80	108,2	338
$3\frac{1}{8}$	25	4.230	338	85	113,8	340
$3\frac{1}{4}$	26	4.360	339	90	118,1	342
$3\frac{3}{8}$	27	4.480	340	95	123,4	343
$3\frac{1}{2}$	28	4.610	341	100	128,3	345
$3\frac{5}{8}$	29	4.730	342	110	139,2	348
$3\frac{3}{4}$	30	4.860	343			
$3\frac{7}{8}$	31	4.980	344			
4	32	5.110	345			
$4\frac{1}{8}$	33	5.230	346			
$4\frac{1}{4}$	34	5.360	347			
$4\frac{3}{8}$	35	5.480	348			
$4\frac{1}{2}$	36	5.610	349			



DISTRIBUTED BY:

Chesterton ISO Certifications available at [www.chesterton.com/corporate/iso](http://www.chesterton.com/corporate/iso)

860 Salem Street  
Groveland, MA 01834 USA  
Telephone: 781-438-7000 Fax: 978-469-6528  
[www.chesterton.com](http://www.chesterton.com)

© 2016 A.W. Chesterton Company.  
® Registered trademark owned and licensed by  
A.W. Chesterton Company in USA and other countries.

FORM NO. 072970 REV. 7

02/16